

<b>DRAWING NUMBER:</b>	<b>09-0066-X-XX</b>
<b>PRODUCT GROUP:</b>	TERMINALS
<b>SUB-GROUP:</b>	COMMERCIAL NON-INSULATED TERMINALS
<b>DESCRIPTION:</b>	NON-INSULATED TURRET TERMINAL

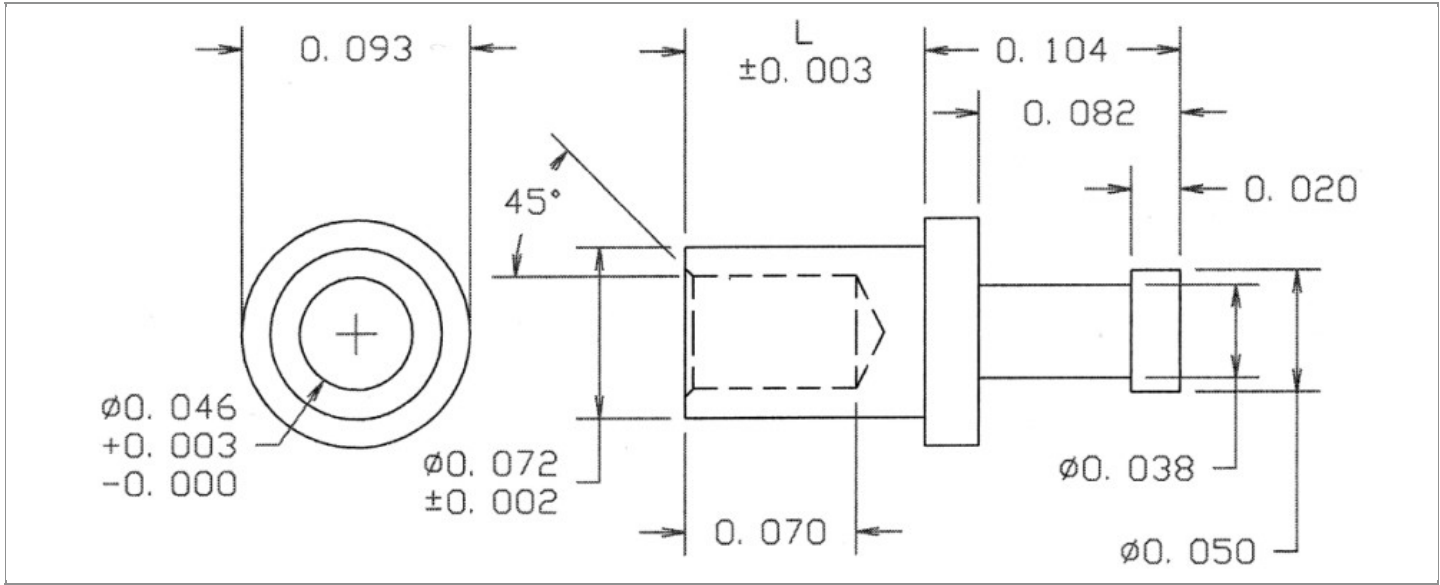

BOARD / PANEL MOUNTING METHOD	MOUNTING HOLE SIZE	DRILL SIZE	FEED THRU COMBINATION
SWAGE MOUNT	0.076" $\pm$ 0.001	#48	N/A

**PART NO. STRUCTURE:**

<b>09-0066</b>	-	<b>X</b>	-	<b>XX</b>
PART SERIES		DIMENSION		FINISH

**MATERIAL OPTIONS:**

**09-0066-X-XX**

COMPONENT	MATERIAL	MATERIAL AND SPECIFICATION
TERMINAL	BRASS	BRASS PER ASTM B16, ALLOY C36000, 1/2 HARD

**DIMENSION OPTIONS:**

**09-0066-X-XX**

DIMENSION	A	D	PIN DIAMETER	OVERALL LENGTH	SHANK LENGTH (L)	BOARD/PANEL THICKNESS
<b>2A</b>	N/A	N/A	N/A	0.202"	0.098"	1/16"
<b>3</b>	N/A	N/A	N/A	0.217"	0.113"	3/32"
<b>4</b>	N/A	N/A	N/A	0.249"	0.145"	1/8"

FINISH - PLATING OPTIONS:

09-0066-X-**XX**

FINISH CODE	COMPONENT	FINISH	FINISH AND SPECIFICATION
01	TERMINAL	SILVER	0.000300"MIN. SILVER PER ASTM B700, TYPE 2, GRADE D WITH A NON-CHROMATE PRESERVATIVE TREATMENT
03	TERMINAL	GOLD	0.000010"MIN. GOLD PER ASTM B488, TYPE II, CODE C OVER 0.000050"MIN. NICKEL PER SAE-AMS-QQ-N-290
035	TERMINAL	GOLD	0.000050"MIN. GOLD PER ASTM B488, TYPE II, CODE C OVER 0.000050"MIN. NICKEL PER SAE-AMS-QQ-N-290
04	TERMINAL	ELECTRO-TIN	0.000300"MIN. ELECTRO-TIN PER ASTM B545 OVER 0.000100"MIN. COPPER PER SAE-AMS-2418
044	TERMINAL	BRIGHT ELECTRO-TIN	0.000300"MIN. BRIGHT ELECTRO-TIN PER ASTM B545 OVER 0.000100"MIN. COPPER PER SAE-AMS-2418
05	TERMINAL	ELECTRO-SOLDER	0.000300"MIN. ELECTRO-SOLDER PER SAE-AMS-P-81728 OVER 0.000100"MIN. COPPER PER SAE-AMS-2418
088	TERMINAL	BRIGHT TIN-LEAD	0.000300"MIN. BRIGHT TIN-LEAD (Sn93%-Pb7%) PER ASTM B545 OVER 0.000100"MIN. COPPER PER SAE-AMS-2418
095	TERMINAL	HOT SOLDER DIP	0.000100"MIN. HOT SOLDER DIP USING Sn60 PER IPC-J-STD-006 OVER 0.000100"MIN. COPPER PER SAE-AMS-2418

TOLERANCES:\*

DECIMAL	FRACTIONAL	ANGULAR	DRAWING ORIGATION DATE	LAST MODIFICATION DATE
± 0.005	± 1/64	± 5 °	6/28/2002	3/1/2017

\*All dimensions are in inches.

RoHS COMPLIANCE:

09-0066-2A-XX

PART NUMBER	RoHS COMPLIANT
09-0066-2A-01	YES
09-0066-2A-03	YES
09-0066-2A-035	YES
09-0066-2A-04	YES
09-0066-2A-044	YES
09-0066-2A-05	NO
09-0066-2A-088	NO
09-0066-2A-095	NO

09-0066-3-XX

PART NUMBER	RoHS COMPLIANT
09-0066-3-01	YES
09-0066-3-03	YES
09-0066-3-035	YES
09-0066-3-04	YES
09-0066-3-044	YES
09-0066-3-05	NO
09-0066-3-088	NO
09-0066-3-095	NO

09-0066-4-XX

PART NUMBER	RoHS COMPLIANT
09-0066-4-01	YES
09-0066-4-03	YES
09-0066-4-035	YES
09-0066-4-04	YES
09-0066-4-044	YES
09-0066-4-05	NO
09-0066-4-088	NO
09-0066-4-095	NO

TOOLING:

INSTALLATION TOOL: ARBOR PRESS	INSTALLATION TOOL: ANVIL (ARBOR PRESS OPERATED)	INSTALLATION TOOL: PRESS-FIT / ROLL SWAGE / RIVET PUNCH (ARBOR PRESS OPERATED)	INSTALLATION TOOL: FLARE SWAGE PUNCH (ARBOR PRESS OPERATED)
TM1	TA94-50-20	TP71-43	TFLP90-150

NOTES:

**DATASHEET NOTES**

N/A

**INSTRUCTION NOTES**

SEE GENERAL SWAGING INSTALLATION INSTRUCTION ON CONCORD ELECTRONICS' WEBSITE [WWW.CONCORD-ELECTRONICS.COM](http://WWW.CONCORD-ELECTRONICS.COM).