

DRAWING NUMBER:	09-9299-1-XXXX
PRODUCT GROUP:	PC JACKS
SUB-GROUP:	INSULATED PC JACKS
DESCRIPTION:	TEST POINT INSULATED JACK - HORIZONTAL MOUNT

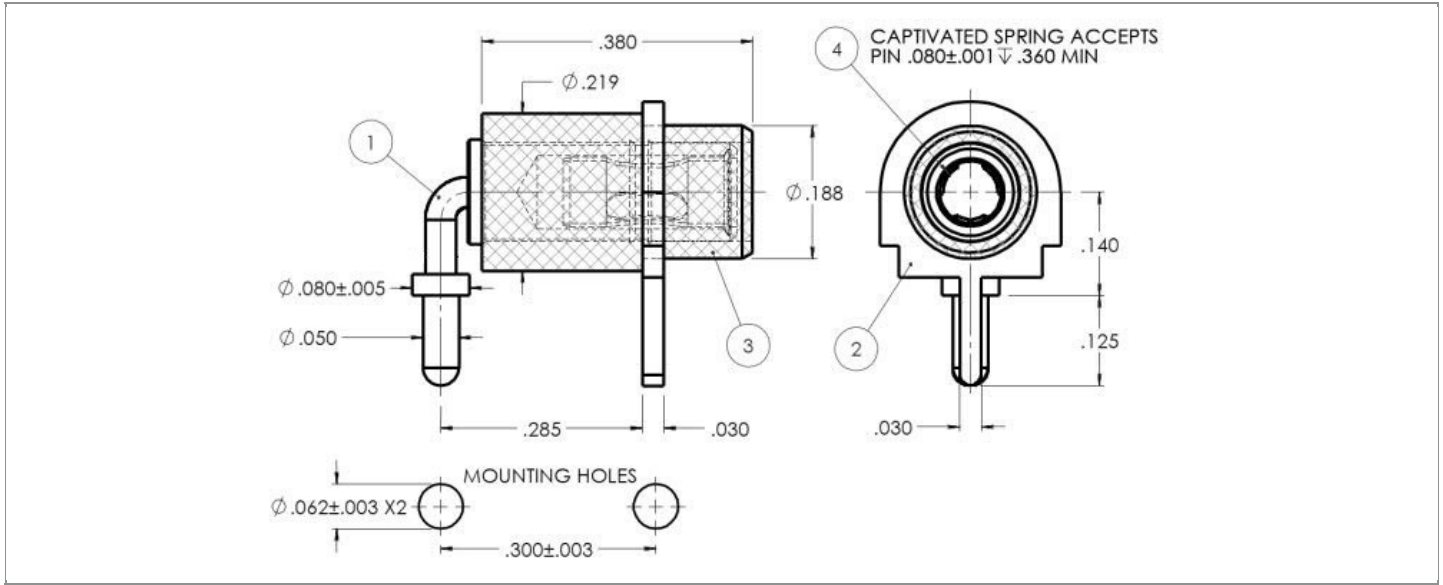

ACCEPTS PIN / PLUG / JACK SIZE	OVERALL LENGTH	MIN. HOLE DEPTH	MOUNTING ORIENTATION
0.080" ± 0.001	0.466"	0.360"	HORIZONTAL
BOARD / PANEL MOUNTING METHOD	MOUNTING HOLE SIZE	BOARD / PANEL THICKNESS	FEED THRU COMBINATION
SOLDER	0.062" ± 0.003	1/32" - 5/32"	N/A

PART NO. STRUCTURE:

09-9299	-	1	-	XX	XX
PART SERIES		DIMENSION		FINISH	INSULATION COLOR

MATERIAL OPTIONS:

09-9299-1-XXXX

COMPONENT	MATERIAL	MATERIAL AND SPECIFICATION
BODY	BRASS	BRASS PER ASTM B16, ALLOY C36000, 1/2 HARD
SPRING (CAGE)	BERYLLIUM COPPER	BERYLLIUM COPPER PER ASTM B194, ALLOY C17200
INSULATION*	PTFE	PTFE PER ASTM D1710
MOUNTING BRACKET	BRASS	BRASS PER ASTM B16, ALLOY C36000, 1/2 HARD

*For Insulation color, please see INSULATION COLOR OPTIONS on Page 2

FINISH - PLATING OPTIONS:

09-9299-1-XXXX

FINISH CODE	COMPONENT	FINISH	FINISH AND SPECIFICATION
035	BODY	GOLD	0.000020"MIN. GOLD PER ASTM B488, TYPE II, CODE C OVER 0.000030"-0.000150" NICKEL PER SAE-AMS-QQ-N-290, CLASS 2
	SPRING (CAGE)	GOLD	0.000050"MIN. GOLD PER ASTM B488, TYPE II, CODE C OVER 0.000030"- 0.000150" NICKEL PER SAE-AMS-QQ-N-290, CLASS 2
	MOUNTING BRACKET	GOLD	0.000020"MIN. GOLD PER ASTM B488, TYPE II, CODE C OVER 0.000030"-0.000150" NICKEL PER SAE-AMS-QQ-N-290, CLASS 2

INSULATION COLOR OPTIONS:

09-9299-1-XXXX

INSULATION COLOR	BLACK	BLUE	BROWN	GRAY	GREEN	ORANGE	RED	VIOLET	WHITE	YELLOW
COLOR CODE NO.	10	16	11	18	15	13	12	17	19	14

TOLERANCES:*

DECIMAL	FRACTIONAL	ANGULAR	DRAWING ORIGATION DATE	LAST MODIFICATION DATE
± 0.010	± 1/64	± 5 °	2/19/2020	2/19/2020

*All dimensions are in inches.

RoHS COMPLIANCE:

09-9299-1-035XX

PART NUMBER	RoHS COMPLIANT
09-9299-1-03510	YES
09-9299-1-03511	NO
09-9299-1-03512	NO
09-9299-1-03513	NO
09-9299-1-03514	NO
09-9299-1-03515	YES
09-9299-1-03516	YES
09-9299-1-03517	YES
09-9299-1-03518	NO
09-9299-1-03519	YES

MILITARY REFERENCE SPECIFICATIONS:

09-9299-1-035XX

PART NUMBER	MIL SPECIFICATION	MIL PART NUMBER
09-9299-1-03510	N/A	N/A
09-9299-1-03511	N/A	N/A

Continued on next page...

MILITARY REFERENCE SPECIFICATIONS CONTINUED:

09-9299-1-035XX

PART NUMBER	MIL SPECIFICATION	MIL PART NUMBER
09-9299-1-03512	N/A	N/A
09-9299-1-03513	N/A	N/A
09-9299-1-03514	N/A	N/A
09-9299-1-03515	N/A	N/A
09-9299-1-03516	N/A	N/A
09-9299-1-03517	N/A	N/A
09-9299-1-03518	N/A	N/A
09-9299-1-03519	N/A	N/A

TOOLING:

INSTALLATION TOOL: ARBOR PRESS	INSTALLATION TOOL: ANVIL (ARBOR PRESS OPERATED)	INSTALLATION TOOL: PRESS-FIT / ROLL SWAGE / RIVET PUNCH (ARBOR PRESS OPERATED)	INSTALLATION TOOL: PRESS-FIT (HAND OPERATED)	CRIMPING TOOL (COMMERCIAL VERSION)
N/A	N/A	N/A	N/A	N/A

NOTES:

DATASHEET NOTES

CLOSED ENTRY CAGE.

INSTRUCTION NOTES

SEE GENERAL PRESS FIT INSTALLATION INSTRUCTION ON CONCORD ELECTRONICS' WEBSITE WWW.CONCORD-ELECTRONICS.COM