

<b>DRAWING NUMBER:</b>	<b>1117-01M-XXXXZ</b>
<b>PRODUCT GROUP:</b>	TERMINALS
<b>SUB-GROUP:</b>	MILITARY INSULATED TERMINALS
<b>DESCRIPTION:</b>	PTFE INSULATED FEED THRU (TURRET/PIN) TERMINAL

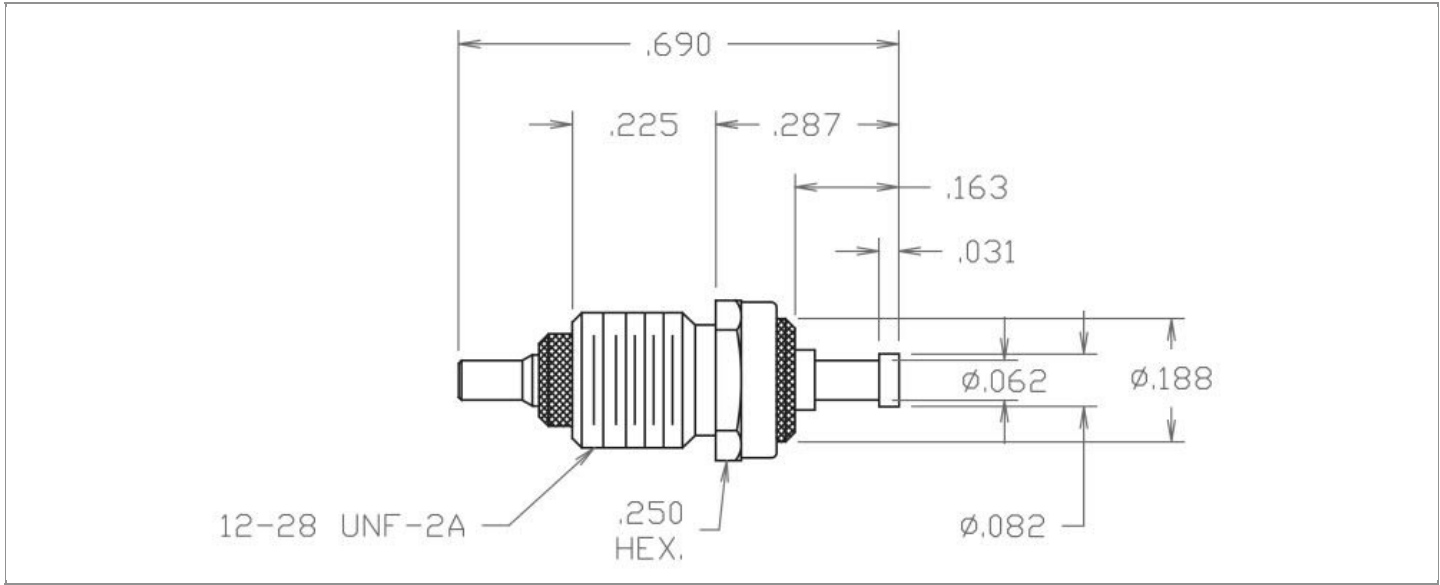

PIN DIAMETER	OVERALL LENGTH	MOUNTING ORIENTATION	BOARD / PANEL MOUNTING METHOD
0.062" $\pm$ 0.005	0.690"	VERTICAL	THREAD MOUNT (12-28 NUT)
BOARD / PANEL THICKNESS	MOUNTING HOLE SIZE	DRILL SIZE	FEED THRU COMBINATION
UP TO 3/32"	0.221" $\pm$ 0.002	#2	TURRET/PIN

**PART NO. STRUCTURE:\***

1117	-	01M	-	XX	XX
PART SERIES		DIMENSION		FINISH	INSULATION COLOR

\*If applicable, "Z" at the end of a PART NO. STRUCTURE indicates TERMINAL MATERIAL TYPE.

**MATERIAL OPTIONS:**

**1117-01M-XXXXZ**

COMPONENT	MATERIAL	MATERIAL AND SPECIFICATION
TERMINAL	PHOSPHOR BRONZE	PHOSPHOR BRONZE PER ASTM B139, ALLOY C54400
BASE/METAL SLEEVE	BRASS	BRASS PER ASTM B16, ALLOY C36000, 1/2 HARD
INSULATION*	PTFE	PTFE PER ASTM D1710
NUT	BRASS	BRASS PER ASTM B16, ALLOY C36000, 1/2 HARD
WASHER	PHOSPHOR BRONZE	PHOSPHOR BRONZE PER MS35333

\*For Insulation color, please see INSULATION COLOR OPTIONS on Page 2

## FINISH - PLATING OPTIONS:

1117-01M-XXXXZ

FINISH CODE	COMPONENT	FINISH	FINISH AND SPECIFICATION
05	TERMINAL	ELECTRO-SOLDER	0.000300"MIN. ELECTRO-SOLDER PER SAE-AMS-P-81728 OVER 0.000100"MIN. COPPER PER SAE-AMS-2418
	BASE/METAL SLEEVE	NICKEL	0.000100"MIN. NICKEL PER SAE-AMS-QQ-N-290
	NUT	NICKEL	0.000100"MIN. NICKEL PER SAE-AMS-QQ-N-290
	WASHER	NICKEL	0.000100"MIN. NICKEL PER SAE-AMS-QQ-N-290
088	TERMINAL	BRIGHT TIN-LEAD	0.000300"MIN. BRIGHT TIN-LEAD (Sn93%-Pb7%) PER ASTM B545 OVER 0.000100"MIN. COPPER PER SAE-AMS-2418
	BASE/METAL SLEEVE	NICKEL	0.000100"MIN. NICKEL PER SAE-AMS-QQ-N-290
	NUT	NICKEL	0.000100"MIN. NICKEL PER SAE-AMS-QQ-N-290
	WASHER	NICKEL	0.000100"MIN. NICKEL PER SAE-AMS-QQ-N-290
095	TERMINAL	HOT SOLDER DIP	0.000100"MIN. HOT SOLDER DIP USING Sn60 PER IPC-J-STD-006 OVER 0.000100"MIN. COPPER PER SAE-AMS-2418
	BASE/METAL SLEEVE	NICKEL	0.000100"MIN. NICKEL PER SAE-AMS-QQ-N-290
	NUT	NICKEL	0.000100"MIN. NICKEL PER SAE-AMS-QQ-N-290
	WASHER	NICKEL	0.000100"MIN. NICKEL PER SAE-AMS-QQ-N-290

## INSULATION COLOR OPTIONS:

1117-01M-XXXXZ

INSULATION COLOR	BLACK	BLUE	BROWN	GRAY	GREEN	ORANGE	RED	VIOLET	WHITE	YELLOW
COLOR CODE NO.	10	16	11	18	15	13	12	17	19	14

## TOLERANCES:\*

DECIMAL	FRACTIONAL	ANGULAR	DRAWING ORIGATION DATE	LAST MODIFICATION DATE
± 0.015	N/A	N/A	2/21/1996	3/1/2017

\*All dimensions are in inches.

RoHS COMPLIANCE:

1117-01M-05XXZ

PART NUMBER	RoHS COMPLIANT
1117-01M-0510Z	NO
1117-01M-0511Z	NO
1117-01M-0512Z	NO
1117-01M-0513Z	NO
1117-01M-0514Z	NO
1117-01M-0515Z	NO
1117-01M-0516Z	NO
1117-01M-0517Z	NO
1117-01M-0518Z	NO
1117-01M-0519Z	NO

1117-01M-088XXZ

PART NUMBER	RoHS COMPLIANT
1117-01M-08810Z	NO
1117-01M-08811Z	NO
1117-01M-08812Z	NO
1117-01M-08813Z	NO
1117-01M-08814Z	NO
1117-01M-08815Z	NO
1117-01M-08816Z	NO
1117-01M-08817Z	NO
1117-01M-08818Z	NO
1117-01M-08819Z	NO

1117-01M-095XXZ

PART NUMBER	RoHS COMPLIANT
1117-01M-09510Z	NO
1117-01M-09511Z	NO
1117-01M-09512Z	NO
1117-01M-09513Z	NO
1117-01M-09514Z	NO
1117-01M-09515Z	NO
1117-01M-09516Z	NO
1117-01M-09517Z	NO
1117-01M-09518Z	NO
1117-01M-09519Z	NO

MILITARY REFERENCE SPECIFICATIONS:

1117-01M-05XXZ

PART NUMBER	MIL SPECIFICATION	MIL PART NUMBER	COMMERCIAL ITEM DESCRIPTION (CID) SPECIFICATION	CID PART NUMBER
1117-01M-0510Z	MIL-T-55155/02	M55155/020B01 (FT020A01Z)	A-A-59126/02	AA59126/020B01
1117-01M-0511Z	MIL-T-55155/02	M55155/021B01 (FT021A01Z)	A-A-59126/02	AA59126/021B01
1117-01M-0512Z	MIL-T-55155/02	M55155/022B01 (FT022A01Z)	A-A-59126/02	AA59126/022B01
1117-01M-0513Z	MIL-T-55155/02	M55155/023B01 (FT023A01Z)	A-A-59126/02	AA59126/023B01
1117-01M-0514Z	MIL-T-55155/02	M55155/024B01 (FT024A01Z)	A-A-59126/02	AA59126/024B01
1117-01M-0515Z	MIL-T-55155/02	M55155/025B01 (FT025A01Z)	A-A-59126/02	AA59126/025B01
1117-01M-0516Z	MIL-T-55155/02	M55155/026B01 (FT026A01Z)	A-A-59126/02	AA59126/026B01
1117-01M-0517Z	MIL-T-55155/02	M55155/027B01 (FT027A01Z)	A-A-59126/02	AA59126/027B01
1117-01M-0518Z	MIL-T-55155/02	M55155/028B01 (FT028A01Z)	A-A-59126/02	AA59126/028B01
1117-01M-0519Z	MIL-T-55155/02	M55155/029B01 (FT029A01Z)	A-A-59126/02	AA59126/029B01

1117-01M-088XXZ

PART NUMBER	MIL SPECIFICATION	MIL PART NUMBER	COMMERCIAL ITEM DESCRIPTION (CID) SPECIFICATION	CID PART NUMBER
1117-01M-08810Z	MIL-T-55155/02	M55155/020D01	A-A-59126/02	AA59126/020D01
1117-01M-08811Z	MIL-T-55155/02	M55155/021D01	A-A-59126/02	AA59126/021D01
1117-01M-08812Z	MIL-T-55155/02	M55155/022D01	A-A-59126/02	AA59126/022D01
1117-01M-08813Z	MIL-T-55155/02	M55155/023D01	A-A-59126/02	AA59126/023D01
1117-01M-08814Z	MIL-T-55155/02	M55155/024D01	A-A-59126/02	AA59126/024D01

Continued on next page...

MILITARY REFERENCE SPECIFICATIONS CONTINUED:

1117-01M-088XXZ

PART NUMBER	MIL SPECIFICATION	MIL PART NUMBER	COMMERCIAL ITEM DESCRIPTION (CID) SPECIFICATION	CID PART NUMBER
1117-01M-08815Z	MIL-T-55155/02	M55155/025D01	A-A-59126/02	AA59126/025D01
1117-01M-08816Z	MIL-T-55155/02	M55155/026D01	A-A-59126/02	AA59126/026D01
1117-01M-08817Z	MIL-T-55155/02	M55155/027D01	A-A-59126/02	AA59126/027D01
1117-01M-08818Z	MIL-T-55155/02	M55155/028D01	A-A-59126/02	AA59126/028D01
1117-01M-08819Z	MIL-T-55155/02	M55155/029D01	A-A-59126/02	AA59126/029D01

1117-01M-095XXZ

PART NUMBER	MIL SPECIFICATION	MIL PART NUMBER	COMMERCIAL ITEM DESCRIPTION (CID) SPECIFICATION	CID PART NUMBER
1117-01M-09510Z	MIL-T-55155/02	M55155/020C01	A-A-59126/02	AA59126/020C01
1117-01M-09511Z	MIL-T-55155/02	M55155/021C01	A-A-59126/02	AA59126/021C01
1117-01M-09512Z	MIL-T-55155/02	M55155/022C01	A-A-59126/02	AA59126/022C01
1117-01M-09513Z	MIL-T-55155/02	M55155/023C01	A-A-59126/02	AA59126/023C01
1117-01M-09514Z	MIL-T-55155/02	M55155/024C01	A-A-59126/02	AA59126/024C01
1117-01M-09515Z	MIL-T-55155/02	M55155/025C01	A-A-59126/02	AA59126/025C01
1117-01M-09516Z	MIL-T-55155/02	M55155/026C01	A-A-59126/02	AA59126/026C01
1117-01M-09517Z	MIL-T-55155/02	M55155/027C01	A-A-59126/02	AA59126/027C01
1117-01M-09518Z	MIL-T-55155/02	M55155/028C01	A-A-59126/02	AA59126/028C01
1117-01M-09519Z	MIL-T-55155/02	M55155/029C01	A-A-59126/02	AA59126/029C01

TOOLING:

INSTALLATION TOOL: ARBOR PRESS	INSTALLATION TOOL: ANVIL (ARBOR PRESS OPERATED)	INSTALLATION TOOL: PRESS-FIT / ROLL SWAGE / RIVET PUNCH (ARBOR PRESS OPERATED)	INSTALLATION TOOL: PRESS-FIT (HAND OPERATED)
N/A	N/A	N/A	N/A

NOTES:

<b>DATASHEET NOTES</b>
------------------------

NUT PART NUMBER: 701-7408-02 WASHER PART NUMBER: 701-7711-02.

<b>INSTRUCTION NOTES</b>
--------------------------

SUPPLIED WITH NICKEL PLATED BRASS HEX NUT (12-28 x 1/4" x 3/32") AND NICKEL PLATED PHOSPHOR BRONZE INTERNAL TOOTH LOCKWASHER.