

DRAWING NUMBER:	1100-07M-XXXX
PRODUCT GROUP:	TERMINALS
SUB-GROUP:	MILITARY INSULATED TERMINALS
DESCRIPTION:	PTFE INSULATED PIN TERMINAL

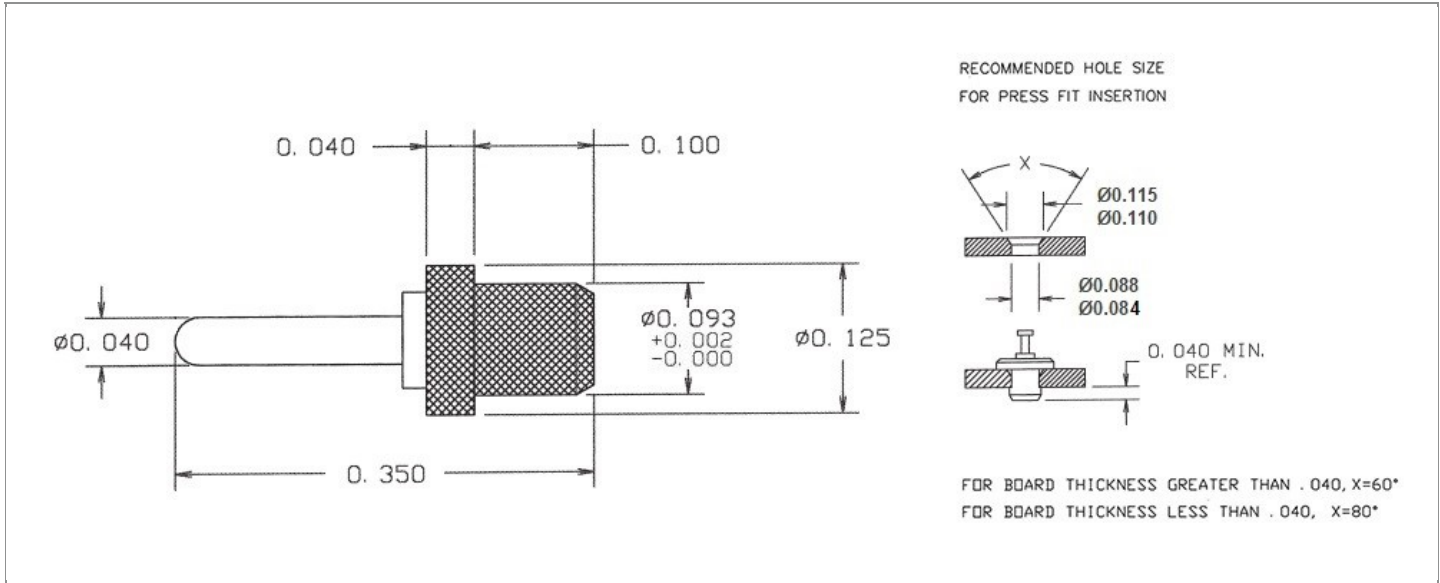

PIN DIAMETER	OVERALL LENGTH	MOUNTING ORIENTATION	BOARD / PANEL MOUNTING METHOD
0.040" ± 0.005	0.350"	VERTICAL	PRESS FIT
BOARD / PANEL THICKNESS	MOUNTING HOLE SIZE	DRILL SIZE	FEED THRU COMBINATION
UP TO 1/16"	0.086" ± 0.002	#44	N/A

PART NO. STRUCTURE:*

1100	-	07M	-	XX	XX
PART SERIES		DIMENSION		FINISH	INSULATION COLOR

*If applicable, "Z" at the end of a PART NO. STRUCTURE indicates TERMINAL MATERIAL TYPE.

MATERIAL OPTIONS:

1100-07M-XXXX

COMPONENT	MATERIAL	MATERIAL AND SPECIFICATION
TERMINAL	BRASS	BRASS PER ASTM B16, ALLOY C36000, 1/2 HARD
BASE/METAL SLEEVE	N/A	N/A
INSULATION*	PTFE	PTFE PER ASTM D1710
NUT	N/A	N/A
WASHER	N/A	N/A

*For Insulation color, please see INSULATION COLOR OPTIONS on Page 2

FINISH - PLATING OPTIONS:

1100-07M-XXXX

FINISH CODE	COMPONENT	FINISH	FINISH AND SPECIFICATION
05	TERMINAL	ELECTRO-SOLDER	0.000300"MIN. ELECTRO-SOLDER PER SAE-AMS-P-81728 OVER 0.000100"MIN. COPPER PER SAE-AMS-2418
	BASE/METAL SLEEVE	N/A	N/A
	NUT	N/A	N/A
	WASHER	N/A	N/A
088	TERMINAL	BRIGHT TIN-LEAD	0.000300"MIN. BRIGHT TIN-LEAD (Sn93%-Pb7%) PER ASTM B545 OVER 0.000100"MIN. COPPER PER SAE-AMS-2418
	BASE/METAL SLEEVE	N/A	N/A
	NUT	N/A	N/A
	WASHER	N/A	N/A
095	TERMINAL	HOT SOLDER DIP	0.000100"MIN. HOT SOLDER DIP USING Sn60 PER IPC-J-STD-006 OVER 0.000100"MIN. COPPER PER SAE-AMS-2418
	BASE/METAL SLEEVE	N/A	N/A
	NUT	N/A	N/A
	WASHER	N/A	N/A

INSULATION COLOR OPTIONS:

1100-07M-XXXX

INSULATION COLOR	BLACK	BLUE	BROWN	GRAY	GREEN	ORANGE	RED	VIOLET	WHITE	YELLOW
COLOR CODE NO.	10	16	11	18	15	13	12	17	19	14

TOLERANCES:*

DECIMAL	FRACTIONAL	ANGULAR	DRAWING ORIENTATION DATE	LAST MODIFICATION DATE
± 0.015	N/A	± 3 °	1/8/1999	1/8/1999

*All dimensions are in inches.

RoHS COMPLIANCE:

1100-07M-05XX

PART NUMBER	RoHS COMPLIANT
1100-07M-0510	NO
1100-07M-0511	NO
1100-07M-0512	NO
1100-07M-0513	NO
1100-07M-0514	NO
1100-07M-0515	NO
1100-07M-0516	NO
1100-07M-0517	NO
1100-07M-0518	NO
1100-07M-0519	NO

1100-07M-088XX

PART NUMBER	RoHS COMPLIANT
1100-07M-08810	NO
1100-07M-08811	NO
1100-07M-08812	NO
1100-07M-08813	NO
1100-07M-08814	NO
1100-07M-08815	NO
1100-07M-08816	NO
1100-07M-08817	NO
1100-07M-08818	NO
1100-07M-08819	NO

1100-07M-095XX

PART NUMBER	RoHS COMPLIANT
1100-07M-09510	NO
1100-07M-09511	NO
1100-07M-09512	NO
1100-07M-09513	NO
1100-07M-09514	NO
1100-07M-09515	NO
1100-07M-09516	NO
1100-07M-09517	NO
1100-07M-09518	NO
1100-07M-09519	NO

MILITARY REFERENCE SPECIFICATIONS:

1100-07M-05XX

PART NUMBER	MIL SPECIFICATION	MIL PART NUMBER	COMMERCIAL ITEM DESCRIPTION (CID) SPECIFICATION	CID PART NUMBER
1100-07M-0510	MIL-T-55155/08	M55155/080H02 (SE080B02S)	A-A-59126/08	AA59126/080H02
1100-07M-0511	MIL-T-55155/08	M55155/081H02 (SE081B02S)	A-A-59126/08	AA59126/081H02
1100-07M-0512	MIL-T-55155/08	M55155/082H02 (SE082B02S)	A-A-59126/08	AA59126/082H02
1100-07M-0513	MIL-T-55155/08	M55155/083H02 (SE083B02S)	A-A-59126/08	AA59126/083H02
1100-07M-0514	MIL-T-55155/08	M55155/084H02 (SE084B02S)	A-A-59126/08	AA59126/084H02
1100-07M-0515	MIL-T-55155/08	M55155/085H02 (SE085B02S)	A-A-59126/08	AA59126/085H02
1100-07M-0516	MIL-T-55155/08	M55155/086H02 (SE086B02S)	A-A-59126/08	AA59126/086H02
1100-07M-0517	MIL-T-55155/08	M55155/087H02 (SE087B02S)	A-A-59126/08	AA59126/087H02
1100-07M-0518	MIL-T-55155/08	M55155/088H02 (SE088B02S)	A-A-59126/08	AA59126/088H02
1100-07M-0519	MIL-T-55155/08	M55155/089H02 (SE089B02S)	A-A-59126/08	AA59126/089H02

1100-07M-088XX

PART NUMBER	MIL SPECIFICATION	MIL PART NUMBER	COMMERCIAL ITEM DESCRIPTION (CID) SPECIFICATION	CID PART NUMBER
1100-07M-08810	MIL-T-55155/08	M55155/080J02	A-A-59126/08	AA59126/080J02 (AA59126/08002)
1100-07M-08811	MIL-T-55155/08	M55155/081J02	A-A-59126/08	AA59126/081J02 (AA59126/08102)
1100-07M-08812	MIL-T-55155/08	M55155/082J02	A-A-59126/08	AA59126/082J02 (AA59126/08202)
1100-07M-08813	MIL-T-55155/08	M55155/083J02	A-A-59126/08	AA59126/083J02 (AA59126/08302)
1100-07M-08814	MIL-T-55155/08	M55155/084J02	A-A-59126/08	AA59126/084J02 (AA59126/08402)

Continued on next page...

MILITARY REFERENCE SPECIFICATIONS CONTINUED:

1100-07M-088XX

PART NUMBER	MIL SPECIFICATION	MIL PART NUMBER	COMMERCIAL ITEM DESCRIPTION (CID) SPECIFICATION	CID PART NUMBER
1100-07M-08815	MIL-T-55155/08	M55155/085J02	A-A-59126/08	AA59126/085J02 (AA59126/08502)
1100-07M-08816	MIL-T-55155/08	M55155/086J02	A-A-59126/08	AA59126/086J02 (AA59126/08602)
1100-07M-08817	MIL-T-55155/08	M55155/087J02	A-A-59126/08	AA59126/087J02 (AA59126/08702)
1100-07M-08818	MIL-T-55155/08	M55155/088J02	A-A-59126/08	AA59126/088J02 (AA59126/08802)
1100-07M-08819	MIL-T-55155/08	M55155/089J02	A-A-59126/08	AA59126/089J02 (AA59126/08902)

1100-07M-095XX

PART NUMBER	MIL SPECIFICATION	MIL PART NUMBER	COMMERCIAL ITEM DESCRIPTION (CID) SPECIFICATION	CID PART NUMBER
1100-07M-09510	MIL-T-55155/08	M55155/080I02	A-A-59126/08	AA59126/080I02
1100-07M-09511	MIL-T-55155/08	M55155/081I02	A-A-59126/08	AA59126/081I02
1100-07M-09512	MIL-T-55155/08	M55155/082I02	A-A-59126/08	AA59126/082I02
1100-07M-09513	MIL-T-55155/08	M55155/083I02	A-A-59126/08	AA59126/083I02
1100-07M-09514	MIL-T-55155/08	M55155/084I02	A-A-59126/08	AA59126/084I02
1100-07M-09515	MIL-T-55155/08	M55155/085I02	A-A-59126/08	AA59126/085I02
1100-07M-09516	MIL-T-55155/08	M55155/086I02	A-A-59126/08	AA59126/086I02
1100-07M-09517	MIL-T-55155/08	M55155/087I02	A-A-59126/08	AA59126/087I02
1100-07M-09518	MIL-T-55155/08	M55155/088I02	A-A-59126/08	AA59126/088I02
1100-07M-09519	MIL-T-55155/08	M55155/089I02	A-A-59126/08	AA59126/089I02

TOOLING:

INSTALLATION TOOL: ARBOR PRESS	INSTALLATION TOOL: ANVIL (ARBOR PRESS OPERATED)	INSTALLATION TOOL: PRESS-FIT / ROLL SWAGE / RIVET PUNCH (ARBOR PRESS OPERATED)	INSTALLATION TOOL: PRESS-FIT (HAND OPERATED)
TM1	TA1100-07	TPI1100-07	TTI1100-07

NOTES:

DATASHEET NOTES

N/A

INSTRUCTION NOTES

SEE GENERAL PRESS FIT INSTALLATION INSTRUCTION ON CONCORD ELECTRONICS' WEBSITE WWW.CONCORD-ELECTRONICS.COM.