

DRAWING NUMBER:	1133-02M-XXXX
PRODUCT GROUP:	TERMINALS
SUB-GROUP:	MILITARY INSULATED TERMINALS
DESCRIPTION:	PTFE INSULATED FEED THRU (DOUBLE TURRET/PIN) TERMINAL

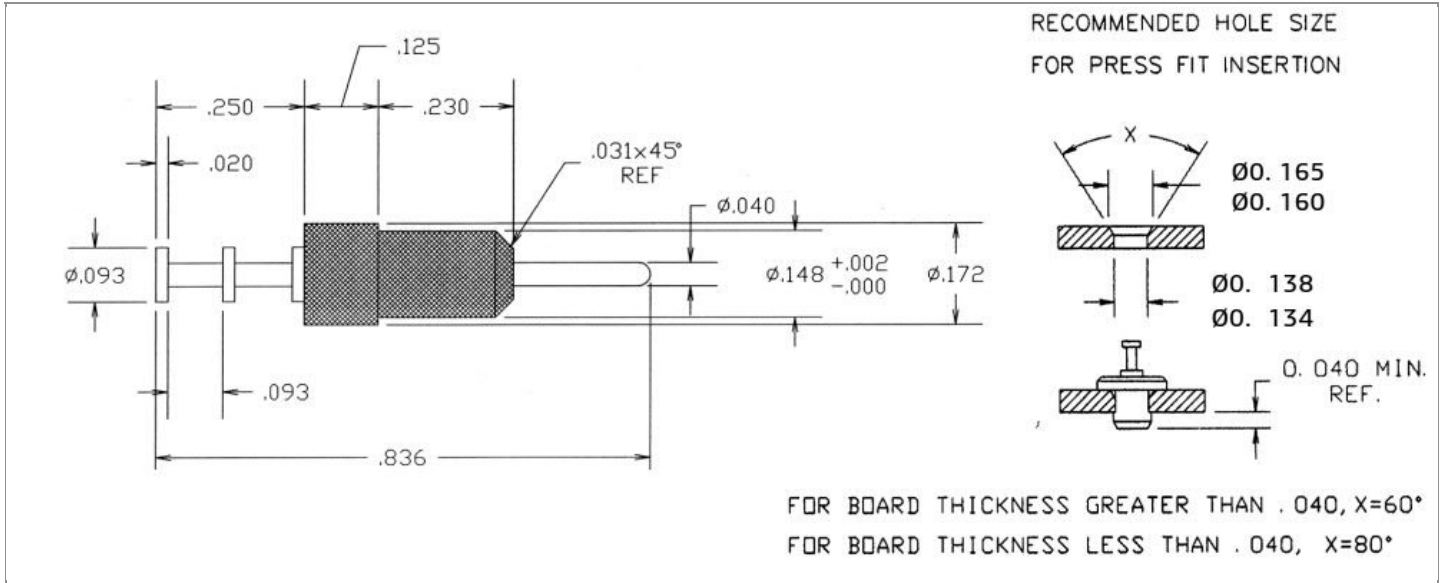

PIN DIAMETER	OVERALL LENGTH	MOUNTING ORIENTATION	BOARD / PANEL MOUNTING METHOD
0.040" ± 0.005	0.836"	VERTICAL	PRESS FIT

BOARD / PANEL THICKNESS	MOUNTING HOLE SIZE	DRILL SIZE	FEED THRU COMBINATION
UP TO 3/16"	0.136" ± 0.002	#29	DOUBLE TURRET/PIN

PART NO. STRUCTURE:*

1133	-	02M	-	XX	XX
PART SERIES		DIMENSION		FINISH	INSULATION COLOR

*If applicable, "Z" at the end of a PART NO. STRUCTURE indicates TERMINAL MATERIAL TYPE.

MATERIAL OPTIONS:

COMPONENT	MATERIAL	MATERIAL AND SPECIFICATION
TERMINAL	BRASS	BRASS PER ASTM B16, ALLOY C36000, 1/2 HARD
BASE/METAL SLEEVE	N/A	N/A
INSULATION*	PTFE	PTFE PER ASTM D1710
NUT	N/A	N/A
WASHER	N/A	N/A

*For Insulation color, please see INSULATION COLOR OPTIONS on Page 2

FINISH - PLATING OPTIONS:

1133-02M-XXXX

FINISH CODE	COMPONENT	FINISH	FINISH AND SPECIFICATION
05	TERMINAL	ELECTRO-SOLDER	0.000300"MIN. ELECTRO-SOLDER PER SAE-AMS-P-81728 OVER 0.000100"MIN. COPPER PER SAE-AMS-2418
	BASE/METAL SLEEVE	N/A	N/A
	NUT	N/A	N/A
	WASHER	N/A	N/A
088	TERMINAL	BRIGHT TIN-LEAD	0.000300"MIN. BRIGHT TIN-LEAD (Sn93%-Pb7%) PER ASTM B545 OVER 0.000100"MIN. COPPER PER SAE-AMS-2418
	BASE/METAL SLEEVE	N/A	N/A
	NUT	N/A	N/A
	WASHER	N/A	N/A
095	TERMINAL	HOT SOLDER DIP	0.000100"MIN. HOT SOLDER DIP USING Sn60 PER IPC-J-STD-006 OVER 0.000100"MIN. COPPER PER SAE-AMS-2418
	BASE/METAL SLEEVE	N/A	N/A
	NUT	N/A	N/A
	WASHER	N/A	N/A

INSULATION COLOR OPTIONS:

1133-02M-XXXX

INSULATION COLOR	BLACK	BLUE	BROWN	GRAY	GREEN	ORANGE	RED	VIOLET	WHITE	YELLOW
COLOR CODE NO.	10	16	11	18	15	13	12	17	19	14

TOLERANCES:*

DECIMAL	FRACTIONAL	ANGULAR	DRAWING ORIENTATION DATE	LAST MODIFICATION DATE
± 0.015	± 1/64	± 3 °	11/14/1996	3/1/2017

*All dimensions are in inches.

RoHS COMPLIANCE:

1133-02M-05XX

PART NUMBER	RoHS COMPLIANT
1133-02M-0510	NO
1133-02M-0511	NO
1133-02M-0512	NO
1133-02M-0513	NO
1133-02M-0514	NO
1133-02M-0515	NO
1133-02M-0516	NO
1133-02M-0517	NO
1133-02M-0518	NO
1133-02M-0519	NO

1133-02M-088XX

PART NUMBER	RoHS COMPLIANT
1133-02M-08810	NO
1133-02M-08811	NO
1133-02M-08812	NO
1133-02M-08813	NO
1133-02M-08814	NO
1133-02M-08815	NO
1133-02M-08816	NO
1133-02M-08817	NO
1133-02M-08818	NO
1133-02M-08819	NO

1133-02M-095XX

PART NUMBER	RoHS COMPLIANT
1133-02M-09510	NO
1133-02M-09511	NO
1133-02M-09512	NO
1133-02M-09513	NO
1133-02M-09514	NO
1133-02M-09515	NO
1133-02M-09516	NO
1133-02M-09517	NO
1133-02M-09518	NO
1133-02M-09519	NO

MILITARY REFERENCE SPECIFICATIONS:

1133-02M-05XX

PART NUMBER	MIL SPECIFICATION	MIL PART NUMBER	COMMERCIAL ITEM DESCRIPTION (CID) SPECIFICATION	CID PART NUMBER
1133-02M-0510	MIL-T-55155/04	M55155/040H02 (FT040B02S)	A-A-59126/04	AA59126/040H02
1133-02M-0511	MIL-T-55155/04	M55155/041H02 (FT041B02S)	A-A-59126/04	AA59126/041H02
1133-02M-0512	MIL-T-55155/04	M55155/042H02 (FT042B02S)	A-A-59126/04	AA59126/042H02
1133-02M-0513	MIL-T-55155/04	M55155/043H02 (FT043B02S)	A-A-59126/04	AA59126/043H02
1133-02M-0514	MIL-T-55155/04	M55155/044H02 (FT044B02S)	A-A-59126/04	AA59126/044H02
1133-02M-0515	MIL-T-55155/04	M55155/045H02 (FT045B02S)	A-A-59126/04	AA59126/045H02
1133-02M-0516	MIL-T-55155/04	M55155/046H02 (FT046B02S)	A-A-59126/04	AA59126/046H02
1133-02M-0517	MIL-T-55155/04	M55155/047H02 (FT047B02S)	A-A-59126/04	AA59126/047H02
1133-02M-0518	MIL-T-55155/04	M55155/048H02 (FT048B02S)	A-A-59126/04	AA59126/048H02
1133-02M-0519	MIL-T-55155/04	M55155/049H02 (FT049B02S)	A-A-59126/04	AA59126/049H02

1133-02M-088XX

PART NUMBER	MIL SPECIFICATION	MIL PART NUMBER	COMMERCIAL ITEM DESCRIPTION (CID) SPECIFICATION	CID PART NUMBER
1133-02M-08810	MIL-T-55155/04	M55155/040J02	A-A-59126/04	AA59126/040J02 (AA59126/04002)
1133-02M-08811	MIL-T-55155/04	M55155/041J02	A-A-59126/04	AA59126/041J02 (AA59126/04102)
1133-02M-08812	MIL-T-55155/04	M55155/042J02	A-A-59126/04	AA59126/042J02 (AA59126/04202)
1133-02M-08813	MIL-T-55155/04	M55155/043J02	A-A-59126/04	AA59126/043J02 (AA59126/04302)
1133-02M-08814	MIL-T-55155/04	M55155/044J02	A-A-59126/04	AA59126/044J02 (AA59126/04402)

Continued on next page...

MILITARY REFERENCE SPECIFICATIONS CONTINUED:

1133-02M-088XX

PART NUMBER	MIL SPECIFICATION	MIL PART NUMBER	COMMERCIAL ITEM DESCRIPTION (CID) SPECIFICATION	CID PART NUMBER
1133-02M-08815	MIL-T-55155/04	M55155/045J02	A-A-59126/04	AA59126/045J02 (AA59126/04502)
1133-02M-08816	MIL-T-55155/04	M55155/046J02	A-A-59126/04	AA59126/046J02 (AA59126/04602)
1133-02M-08817	MIL-T-55155/04	M55155/047J02	A-A-59126/04	AA59126/047J02 (AA59126/04702)
1133-02M-08818	MIL-T-55155/04	M55155/048J02	A-A-59126/04	AA59126/048J02 (AA59126/04802)
1133-02M-08819	MIL-T-55155/04	M55155/049J02	A-A-59126/04	AA59126/049J02 (AA59126/04902)

1133-02M-095XX

PART NUMBER	MIL SPECIFICATION	MIL PART NUMBER	COMMERCIAL ITEM DESCRIPTION (CID) SPECIFICATION	CID PART NUMBER
1133-02M-09510	MIL-T-55155/04	M55155/040I02	A-A-59126/04	AA59126/040I02
1133-02M-09511	MIL-T-55155/04	M55155/041I02	A-A-59126/04	AA59126/041I02
1133-02M-09512	MIL-T-55155/04	M55155/042I02	A-A-59126/04	AA59126/042I02
1133-02M-09513	MIL-T-55155/04	M55155/043I02	A-A-59126/04	AA59126/043I02
1133-02M-09514	MIL-T-55155/04	M55155/044I02	A-A-59126/04	AA59126/044I02
1133-02M-09515	MIL-T-55155/04	M55155/045I02	A-A-59126/04	AA59126/045I02
1133-02M-09516	MIL-T-55155/04	M55155/046I02	A-A-59126/04	AA59126/046I02
1133-02M-09517	MIL-T-55155/04	M55155/047I02	A-A-59126/04	AA59126/047I02
1133-02M-09518	MIL-T-55155/04	M55155/048I02	A-A-59126/04	AA59126/048I02
1133-02M-09519	MIL-T-55155/04	M55155/049I02	A-A-59126/04	AA59126/049I02

TOOLING:

INSTALLATION TOOL: ARBOR PRESS	INSTALLATION TOOL: ANVIL (ARBOR PRESS OPERATED)	INSTALLATION TOOL: PRESS-FIT / ROLL SWAGE / RIVET PUNCH (ARBOR PRESS OPERATED)	INSTALLATION TOOL: PRESS-FIT (HAND OPERATED)
TM1	TA1133-02	TPI1133-02	TTI1133-02

NOTES:

DATASHEET NOTES

N/A

INSTRUCTION NOTES

SEE GENERAL PRESS FIT INSTALLATION INSTRUCTION ON CONCORD ELECTRONICS' WEBSITE WWW.CONCORD-ELECTRONICS.COM.