

DRAWING NUMBER:	15-402-X-XX
PRODUCT GROUP:	TERMINALS
SUB-GROUP:	MILITARY NON-INSULATED TERMINALS
DESCRIPTION:	NON-INSULATED THRU-HOLE KNURLED SLOTTED TERMINAL

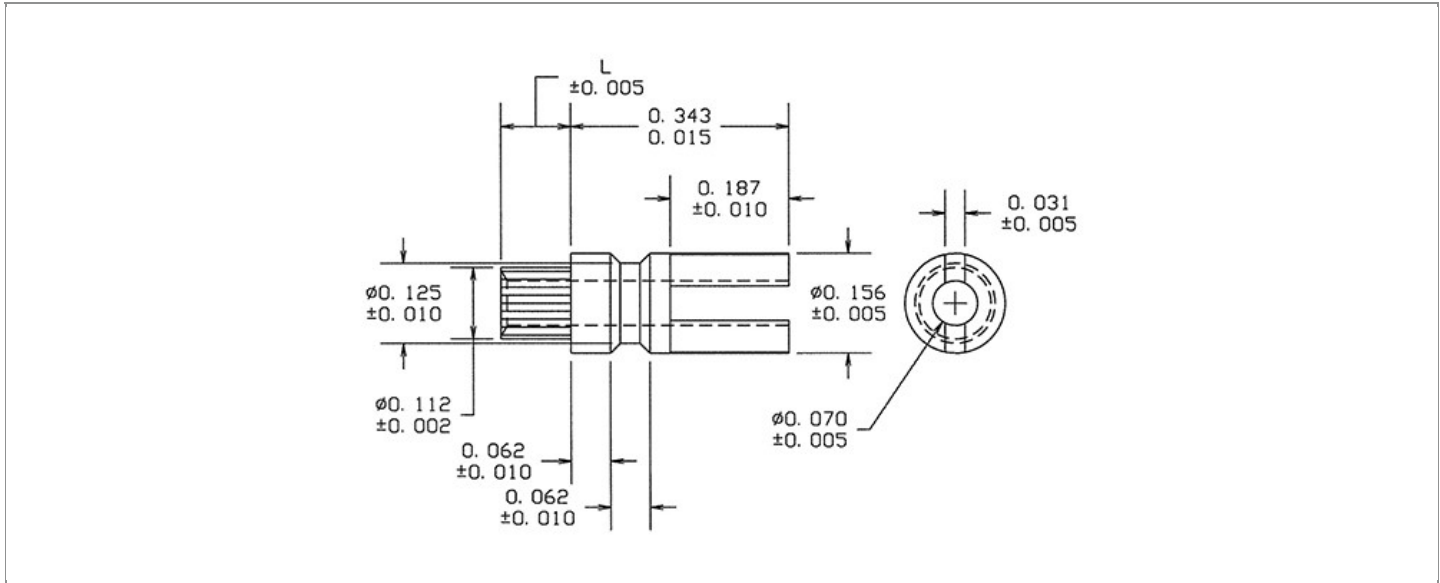

BOARD / PANEL MOUNTING METHOD	MOUNTING HOLE SIZE	DRILL SIZE	FEED THRU COMBINATION
SWAGE MOUNT	0.116" ± 0.001	#32	N/A

PART NO. STRUCTURE:

15-402 - X - XX
 PART SERIES DIMENSION FINISH

MATERIAL OPTIONS:

15-402-X-XX

COMPONENT	MATERIAL	MATERIAL AND SPECIFICATION
TERMINAL	BRASS	BRASS PER ASTM B16, ALLOY C36000, 1/2 HARD

DIMENSION OPTIONS:

15-402-X-XX

DIMENSION	K	OVERALL LENGTH	SHANK LENGTH (L)	BOARD/PANEL THICKNESS
2	N/A	0.452"	0.109"	1/16"
3	N/A	0.483"	0.140"	3/32"
4	N/A	0.514"	0.171"	1/8"

FINISH - PLATING OPTIONS:

15-402-X-XX

FINISH CODE	COMPONENT	FINISH	FINISH AND SPECIFICATION
05	TERMINAL	ELECTRO-SOLDER	0.000300"MIN. ELECTRO-SOLDER PER SAE-AMS-P-81728 OVER 0.000100"MIN. COPPER PER SAE-AMS-2418
088	TERMINAL	BRIGHT TIN-LEAD	0.000300"MIN. BRIGHT TIN-LEAD (Sn93%-Pb7%) PER ASTM B545 OVER 0.000100"MIN. COPPER PER SAE-AMS-2418
095	TERMINAL	BRIGHT TIN-LEAD	0.000300"MIN. BRIGHT TIN-LEAD (Sn93%-Pb7%) PER ASTM B545 OVER 0.000100"MIN. COPPER PER SAE-AMS-2418
	TERMINAL	HOT SOLDER DIP	0.000100"MIN. HOT SOLDER DIP USING Sn60 PER IPC-J-STD-006 OVER 0.000100"MIN. COPPER PER SAE-AMS-2418

TOLERANCES:*

DECIMAL	FRACTIONAL	ANGULAR	DRAWING ORIGATION DATE	LAST MODIFICATION DATE
± 0.005	N/A	N/A	2/4/2001	3/1/2017

*All dimensions are in inches.

RoHS COMPLIANCE:

15-402-2-XX

PART NUMBER	RoHS COMPLIANT
15-402-2-05	NO
15-402-2-088	NO
15-402-2-095	NO

15-402-3-XX

PART NUMBER	RoHS COMPLIANT
15-402-3-05	NO
15-402-3-088	NO
15-402-3-095	NO

15-402-4-XX

PART NUMBER	RoHS COMPLIANT
15-402-4-05	NO
15-402-4-088	NO
15-402-4-095	NO

MILITARY REFERENCE SPECIFICATIONS:

15-402-2-XX

PART NUMBER	MIL SPECIFICATION	MIL PART NUMBER	COMMERCIAL ITEM DESCRIPTION (CID) SPECIFICATION	CID PART NUMBER
15-402-2-05	MIL-T-55155/32	M55155/32XH01 (M55155/32-1S; SE32XC01S)	A-A-59126/32	AA59126/32XH01
15-402-2-088	MIL-T-55155/32	M55155/32XJ01	A-A-59126/32	AA59126/32XJ01 (AA59126/3201)
15-402-2-095	MIL-T-55155/32	M55155/32XI01	A-A-59126/32	AA59126/32XI01

15-402-3-XX

PART NUMBER	MIL SPECIFICATION	MIL PART NUMBER	COMMERCIAL ITEM DESCRIPTION (CID) SPECIFICATION	CID PART NUMBER
15-402-3-05	MIL-T-55155/32	M55155/32XH03 (M55155/32-3S; SE32XC03S)	A-A-59126/32	AA59126/32XH03
15-402-3-088	MIL-T-55155/32	M55155/32XJ03	A-A-59126/32	AA59126/32XJ03 (AA59126/3203)
15-402-3-095	MIL-T-55155/32	M55155/32XI03	A-A-59126/32	AA59126/32XI03

Continued on next page...

MILITARY REFERENCE SPECIFICATIONS CONTINUED:

15-402-4-XX

PART NUMBER	MIL SPECIFICATION	MIL PART NUMBER	COMMERCIAL ITEM DESCRIPTION (CID) SPECIFICATION	CID PART NUMBER
15-402-4-05	MIL-T-55155/32	M55155/32XH06 (M55155/32-6S; SE32XC06S)	A-A-59126/32	AA59126/32XH06
15-402-4-088	MIL-T-55155/32	M55155/32XJ06	A-A-59126/32	AA59126/32XJ06 (AA59126/3206)
15-402-4-095	MIL-T-55155/32	M55155/32XI06	A-A-59126/32	AA59126/32XI06

TOOLING:

INSTALLATION TOOL: ARBOR PRESS	INSTALLATION TOOL: ANVIL (ARBOR PRESS OPERATED)	INSTALLATION TOOL: PRESS-FIT / ROLL SWAGE / RIVET PUNCH (ARBOR PRESS OPERATED)	INSTALLATION TOOL: FLARE SWAGE PUNCH (ARBOR PRESS OPERATED)
TM1	TA10-402	TP112-70	TFLP90-200

NOTES:

DATASHEET NOTES

N/A

INSTRUCTION NOTES

SEE GENERAL SWAGING INSTALLATION INSTRUCTION ON CONCORD ELECTRONICS' WEBSITE WWW.CONCORD-ELECTRONICS.COM