

DRAWING NUMBER:	01-2406-X-XX
PRODUCT GROUP:	BANANA PLUGS, JACKS AND PHONE TIPS
SUB-GROUP:	NON-INSULATED BANANA JACKS
DESCRIPTION:	NON-INSULATED MINIATURE BANANA PANEL JACK

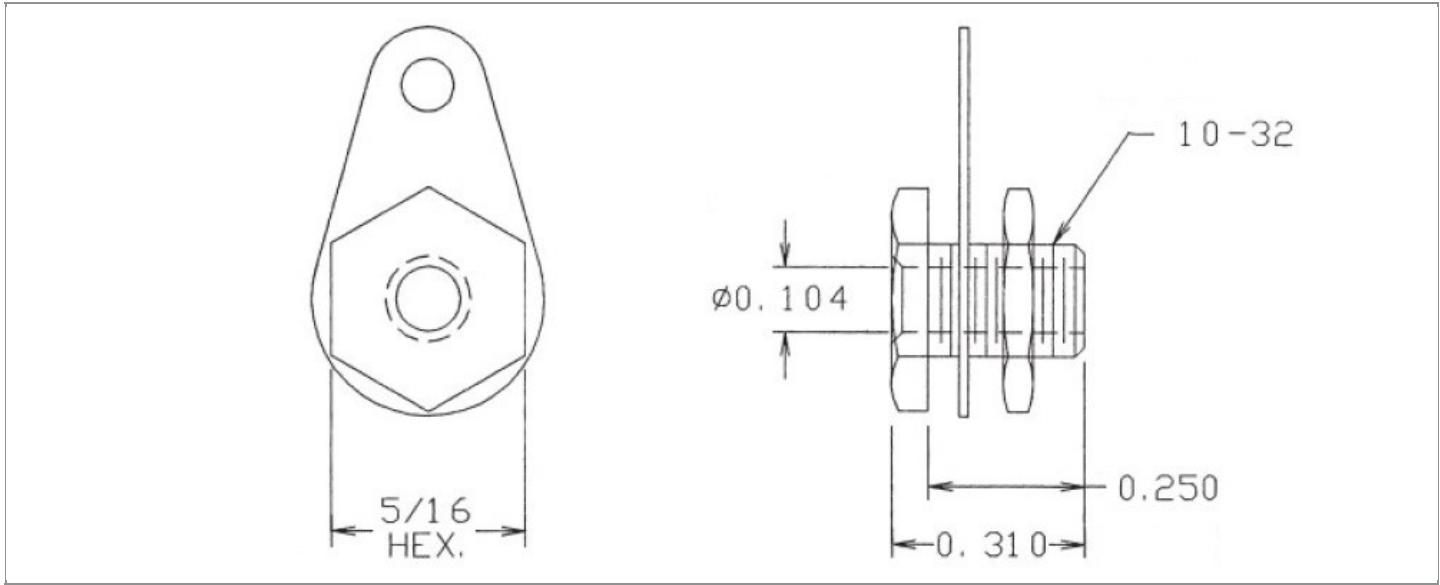

ACCEPTS PIN / PLUG / JACK SIZE	BOARD / PANEL MOUNTING METHOD	MOUNTING HOLE SIZE	DRILL SIZE
MINIATURE BANANA PLUG	THREAD MOUNT (10-32 NUT)	0.196"	#9

PART NO. STRUCTURE:

01-2406	-	1	-	XX
PART SERIES		DIMENSION		FINISH

MATERIAL OPTIONS:

01-2406-1-XX

COMPONENT	MATERIAL	MATERIAL AND SPECIFICATION
BODY	BRASS	BRASS PER ASTM B16, ALLOY C36000, 1/2 HARD
NUT	BRASS	BRASS PER ASTM B16, ALLOY C36000, 1/2 HARD
LUG	COPPER	COPPER PER ASTM B152, ALLOY C11000, 1/2 HARD

DIMENSION OPTIONS:

01-2406-1-XX

DIMENSION	OVERALL LENGTH	MIN. HOLE DEPTH	SHANK LENGTH (L)	BOARD/PANEL THICKNESS
1	0.310"	0.310"	0.312"	UP TO 1/8"

FINISH - PLATING OPTIONS:

01-2406-1-XX

FINISH CODE	COMPONENT	FINISH	FINISH AND SPECIFICATION
02	BODY	NICKEL	0.000100"MIN. NICKEL PER SAE-AMS-QQ-N-290
	NUT	NICKEL	0.000100"MIN. NICKEL PER SAE-AMS-QQ-N-290
	LUG	ELECTRO-TIN	0.000150"MIN. ELECTRO-TIN PER ASTM B545
03	BODY	GOLD	0.000010"MIN. GOLD PER ASTM B488, TYPE II, CODE C OVER 0.000050"MIN. NICKEL PER SAE-AMS-QQ-N-290
	NUT	NICKEL	0.000100"MIN. NICKEL PER SAE-AMS-QQ-N-290
	LUG	ELECTRO-TIN	0.000150"MIN. ELECTRO-TIN PER ASTM B545
044	BODY	BRIGHT ELECTRO-TIN	0.000300"MIN. BRIGHT ELECTRO-TIN PER ASTM B545 OVER 0.000100"MIN. COPPER PER SAE-AMS-2418
	NUT	NICKEL	0.000100"MIN. NICKEL PER SAE-AMS-QQ-N-290
	LUG	ELECTRO-TIN	0.000150"MIN. ELECTRO-TIN PER ASTM B545

TOLERANCES:*

DECIMAL	FRACTIONAL	ANGULAR	DRAWING ORIENTATION DATE	LAST MODIFICATION DATE
± 0.010	± 1/64	N/A	10/28/1996	4/1/2017

*All dimensions are in inches.

RoHS COMPLIANCE:

01-2406-1-XX

PART NUMBER	RoHS COMPLIANT
01-2406-1-02	YES
01-2406-1-03	YES
01-2406-1-044	YES

TOOLING:

INSTALLATION TOOL: ARBOR PRESS	INSTALLATION TOOL: ANVIL (ARBOR PRESS OPERATED)	INSTALLATION TOOL: PRESS-FIT / ROLL SWAGE / RIVET PUNCH (ARBOR PRESS OPERATED)
N/A	N/A	N/A

NOTES:

DATASHEET NOTES

RATED FOR 15 AMPERES CONTINUOUS DUTY. ACCEPTS MINIATURE BANANA PLUG. NUT PART NUMBER: 701-7325-02. LUG PART NUMBER: 707-0020.

INSTRUCTION NOTES

SUPPLIED WITH NICKEL PLATED BRASS HEX NUT (10-32 x 5/16" x 7/64") AND ELECTRO-TIN PLATED COPPER #10 SOLDER LUG.
