

DRAWING NUMBER:	09-0351-1-XX
PRODUCT GROUP:	TERMINALS
SUB-GROUP:	COMMERCIAL NON-INSULATED WIRE APPLIED PIN TERMINALS
DESCRIPTION:	NON-INSULATED PIN TERMINAL WITH SOLDER CUP

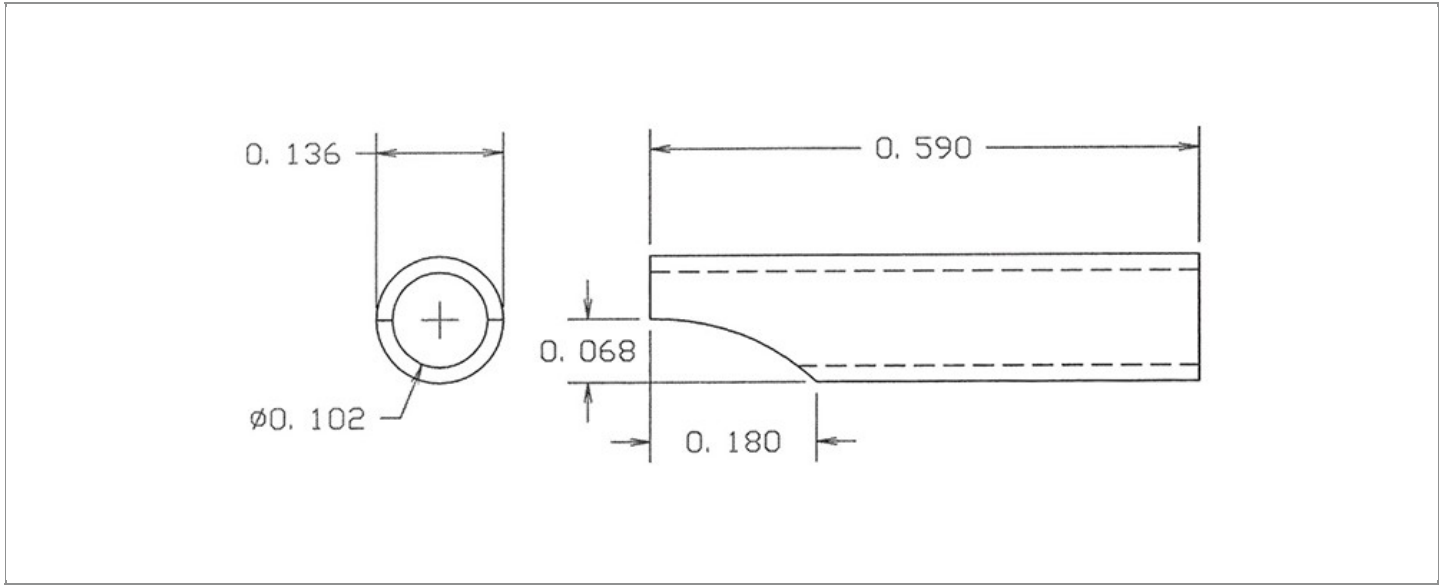

CABLE / WIRE SIZE	PIN DIAMETER	OVERALL LENGTH	MIN. HOLE DEPTH
16 AWG	0.136" ± 0.005	0.590"	0.590"

PART NO. STRUCTURE:

09-0351	-	1	-	XX
PART SERIES		DIMENSION		FINISH

MATERIAL OPTIONS:

09-0351-1-XX

COMPONENT	MATERIAL	MATERIAL AND SPECIFICATION
PIN	BRASS	BRASS PER ASTM B16, ALLOY C36000, 1/2 HARD

FINISH - PLATING OPTIONS:

09-0351-1-XX

FINISH CODE	COMPONENT	FINISH	FINISH AND SPECIFICATION
03	PIN	GOLD	0.000010"MIN. GOLD PER ASTM B488, TYPE II, CODE C OVER 0.000050"MIN. NICKEL PER SAE-AMS-QQ-N-290
035	PIN	GOLD	0.000050"MIN. GOLD PER ASTM B488, TYPE II, CODE C OVER 0.000050"MIN. NICKEL PER SAE-AMS-QQ-N-290
04	PIN	ELECTRO-TIN	0.000300"MIN. ELECTRO-TIN PER ASTM B545 OVER 0.000100"MIN. COPPER PER SAE-AMS-2418
044	PIN	BRIGHT ELECTRO-TIN	0.000300"MIN. BRIGHT ELECTRO-TIN PER ASTM B545 OVER 0.000100"MIN. COPPER PER SAE-AMS-2418

Continued on next page...

FINISH - PLATING OPTIONS CONTINUED:

09-0351-1-XX

FINISH CODE	COMPONENT	FINISH	FINISH AND SPECIFICATION
05	PIN	ELECTRO-SOLDER	0.000300"MIN. ELECTRO-SOLDER PER SAE-AMS-P-81728 OVER 0.000100"MIN. COPPER PER SAE-AMS-2418
088	PIN	BRIGHT TIN-LEAD	0.000300"MIN. BRIGHT TIN-LEAD (Sn93%-Pb7%) PER ASTM B545 OVER 0.000100"MIN. COPPER PER SAE-AMS-2418

TOLERANCES:*

DECIMAL	FRACTIONAL	ANGULAR	DRAWING ORIGATION DATE	LAST MODIFICATION DATE
± 0.005	± 1/64	± 5°	9/17/2004	3/1/2017

*All dimensions are in inches.

RoHS COMPLIANCE:

09-0351-1-XX

PART NUMBER	RoHS COMPLIANT
09-0351-1-03	YES
09-0351-1-035	YES
09-0351-1-04	YES
09-0351-1-044	YES
09-0351-1-05	NO
09-0351-1-088	NO

TOOLING:

CRIMPING TOOL (COMMERCIAL VERSION)
N/A

NOTES:

DATASHEET NOTES RECOMMENDED WIRE FOR SOLDERING: 16 AWG, 7 STRAND, NO. 24 COPPER WIRE, PTFE INSULATED. MINIMUM HOLE DEPTH: 0.590".
INSTRUCTION NOTES STRIP INSULATION OF 16 AWG WIRE TO LENGTH OF MIN. HOLE DEPTH OF BARREL AND INSERT IT INTO END HOLE OF PIN AND SOLDER.