

|                        |                         |
|------------------------|-------------------------|
| <b>DRAWING NUMBER:</b> | <b>09-9689-X-XX</b>     |
| <b>PRODUCT GROUP:</b>  | PC JACKS                |
| <b>SUB-GROUP:</b>      | NON-INSULATED PC JACKS  |
| <b>DESCRIPTION:</b>    | PC JACK - NON-INSULATED |

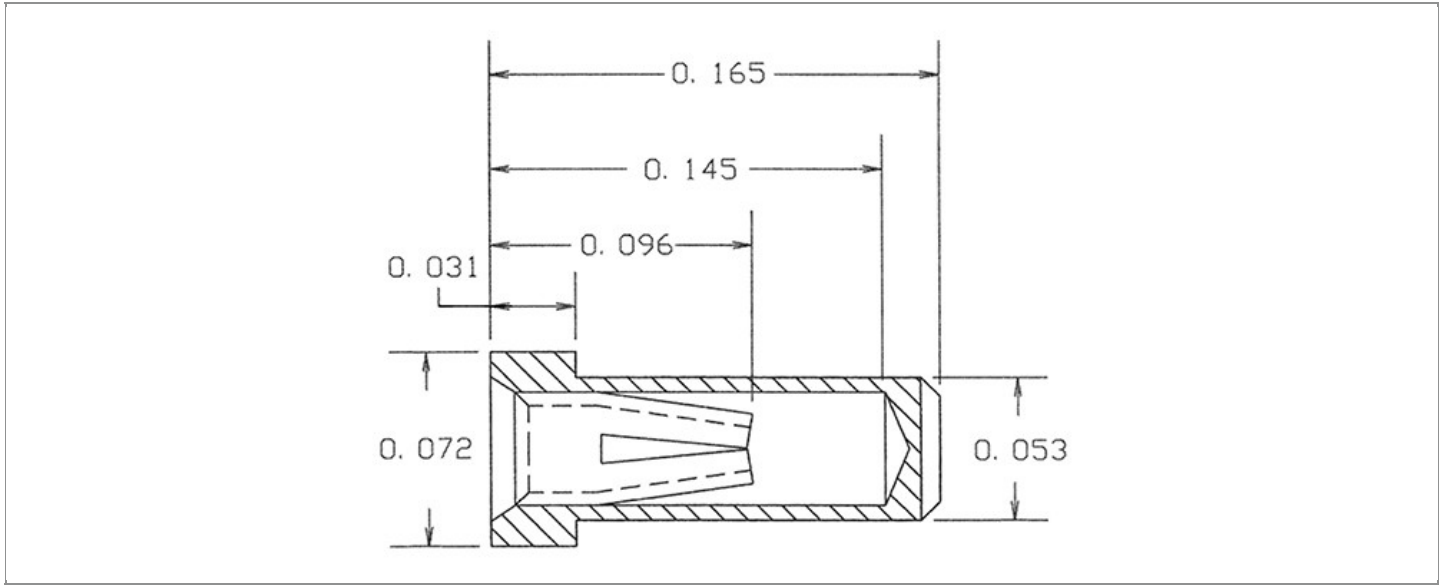

| ACCEPTS<br>PIN / PLUG / JACK SIZE | MOUNTING<br>ORIENTATION | BOARD / PANEL<br>MOUNTING METHOD | MOUNTING<br>HOLE SIZE | DRILL<br>SIZE | FEED THRU COMBINATION |
|-----------------------------------|-------------------------|----------------------------------|-----------------------|---------------|-----------------------|
| 0.015" - 0.025"                   | VERTICAL                | SOLDER                           | 0.056" ± 0.001        | #54           | N/A                   |

**PART NO. STRUCTURE:**

**09-9689** - **1** - **XX**  
 PART SERIES    DIMENSION    FINISH

**MATERIAL OPTIONS:**

**09-9689-1-XX**

| COMPONENT               | MATERIAL         | MATERIAL AND SPECIFICATION                   |
|-------------------------|------------------|--|
| <b>BODY</b>             | BRASS            | BRASS PER ASTM B16, ALLOY C36000, 1/2 HARD   |
| <b>SPRING (CAGE)</b>    | BERYLLIUM COPPER | BERYLLIUM COPPER PER ASTM B194, ALLOY C17200 |
| <b>MOUNTING BRACKET</b> | N/A              | N/A  |

DIMENSION OPTIONS:

09-9689-1-XX

| DIMENSION | A   | H   | OVERALL LENGTH | MIN. HOLE DEPTH | SHANK LENGTH (L) | BOARD/PANEL THICKNESS |
|-----------|-----|-----|----------------|-----------------|------------------|-----------------------|
| 1         | N/A | N/A | 0.165"         | 0.145"          | N/A              | 1/32" - 3/32"         |

FINISH - PLATING OPTIONS:

09-9689-1-XX

| FINISH CODE | COMPONENT        | FINISH             | FINISH AND SPECIFICATION   |
|-------------|------------------|--------------------|--|
| 03          | BODY             | GOLD               | 0.000010"MIN. GOLD PER ASTM B488, TYPE II, CODE C OVER 0.000100"MIN. NICKEL PER SAE-AMS-QQ-N-290, CLASS 2        |
|             | SPRING (CAGE)    | GOLD               | 0.000030"MIN. GOLD PER ASTM B488, TYPE II, CODE C OVER 0.000100"MIN. NICKEL PER SAE-AMS-QQ-N-290, CLASS 2        |
|             | MOUNTING BRACKET | N/A                | N/A  |
| 035         | BODY             | GOLD               | 0.000020"MIN. GOLD PER ASTM B488, TYPE II, CODE C OVER 0.000100"MIN. NICKEL PER SAE-AMS-QQ-N-290, CLASS 2        |
|             | SPRING (CAGE)    | GOLD               | 0.000050"MIN. GOLD PER ASTM B488, TYPE II, CODE C OVER 0.000100"MIN. NICKEL PER SAE-AMS-QQ-N-290, CLASS 2        |
|             | MOUNTING BRACKET | N/A                | N/A  |
| 04          | BODY             | ELECTRO-TIN        | 0.000100"MIN. ELECTRO-TIN PER ASTM B545 OVER 0.000100"MIN. NICKEL PER SAE-AMS-QQ-N-290, CLASS 2                  |
|             | SPRING (CAGE)    | BRIGHT ELECTRO-TIN | 0.000200"MIN. BRIGHT ELECTRO-TIN PER ASTM B545 OVER 0.000050"MIN. NICKEL PER SAE-AMS-QQ-N-290, CLASS 2           |
|             | MOUNTING BRACKET | N/A                | N/A  |
| 06          | BODY             | ELECTRO-TIN        | 0.000100"MIN. ELECTRO-TIN PER ASTM B545 OVER 0.000100"MIN. NICKEL PER SAE-AMS-QQ-N-290, CLASS 2                  |
|             | SPRING (CAGE)    | GOLD               | 0.000030"MIN. GOLD PER ASTM B488, TYPE II, CODE C OVER 0.000100"MIN. NICKEL PER SAE-AMS-QQ-N-290, CLASS 2        |
|             | MOUNTING BRACKET | N/A                | N/A  |
| 063         | BODY             | BRIGHT TIN-LEAD    | 0.000200"MIN. BRIGHT TIN-LEAD (Sn93%-Pb7%) PER ASTM B545 OVER 0.000100"MIN. NICKEL PER SAE-AMS-QQ-N-290, CLASS 2 |
|             | SPRING (CAGE)    | GOLD               | 0.000030"MIN. GOLD PER ASTM B488, TYPE II, CODE C OVER 0.000100"MIN. NICKEL PER SAE-AMS-QQ-N-290, CLASS 2        |
|             | MOUNTING BRACKET | N/A                | N/A  |
| 088         | BODY             | BRIGHT TIN-LEAD    | 0.000200"MIN. BRIGHT TIN-LEAD (Sn93%-Pb7%) PER ASTM B545 OVER 0.000100"MIN. NICKEL PER SAE-AMS-QQ-N-290, CLASS 2 |
|             | SPRING (CAGE)    | BRIGHT TIN-LEAD    | 0.000200"MIN. BRIGHT TIN-LEAD (Sn93%-Pb7%) PER ASTM B545 OVER 0.000100"MIN. NICKEL PER SAE-AMS-QQ-N-290, CLASS 2 |
|             | MOUNTING BRACKET | N/A                | N/A  |

TOLERANCES:\*

| DECIMAL | FRACTIONAL | ANGULAR | DRAWING ORIENTATION DATE | LAST MODIFICATION DATE |
|---------|------------|---------|--------------------------|------------------------|
| ± 0.005 | ± 1/64     | ± 5 °   | 05/25/00                 | 01/01/17               |

\*All dimensions are in inches.

RoHS COMPLIANCE:

09-9689-1-XX

| PART NUMBER   | RoHS COMPLIANT |
|---------------|----------------|
| 09-9689-1-03  | YES            |
| 09-9689-1-035 | YES            |
| 09-9689-1-04  | YES            |
| 09-9689-1-06  | YES            |
| 09-9689-1-063 | NO             |
| 09-9689-1-088 | NO             |

TOOLING:

| INSTALLATION TOOL:<br>ARBOR PRESS | INSTALLATION TOOL:<br>ANVIL<br>(ARBOR PRESS OPERATED) | INSTALLATION TOOL:<br>PRESS-FIT / ROLL SWAGE<br>/ RIVET PUNCH<br>(ARBOR PRESS OPERATED) | CRIMPING TOOL<br>(COMMERCIAL VERSION) |
|-----------------------------------|---|---|---------------------------------------|
| N/A                               | N/A   | N/A   | N/A                                   |

NOTES:

| DATASHEET NOTES  |
|--|
| THE MINIMUM PIN DIAMETER SHOULD BE NO MORE THAN 0.005" SMALLER THAN THE MAXIMUM PIN DIAMETER INSERTED. |
| INSTRUCTION NOTES  |
| N/A  |