

<b>DRAWING NUMBER:</b>	<b>09-9059-1-XXXX</b>
<b>PRODUCT GROUP:</b>	PC JACKS
<b>SUB-GROUP:</b>	INSULATED PC JACKS
<b>DESCRIPTION:</b>	JACK FOR PATCH CORD ASSEMBLIES

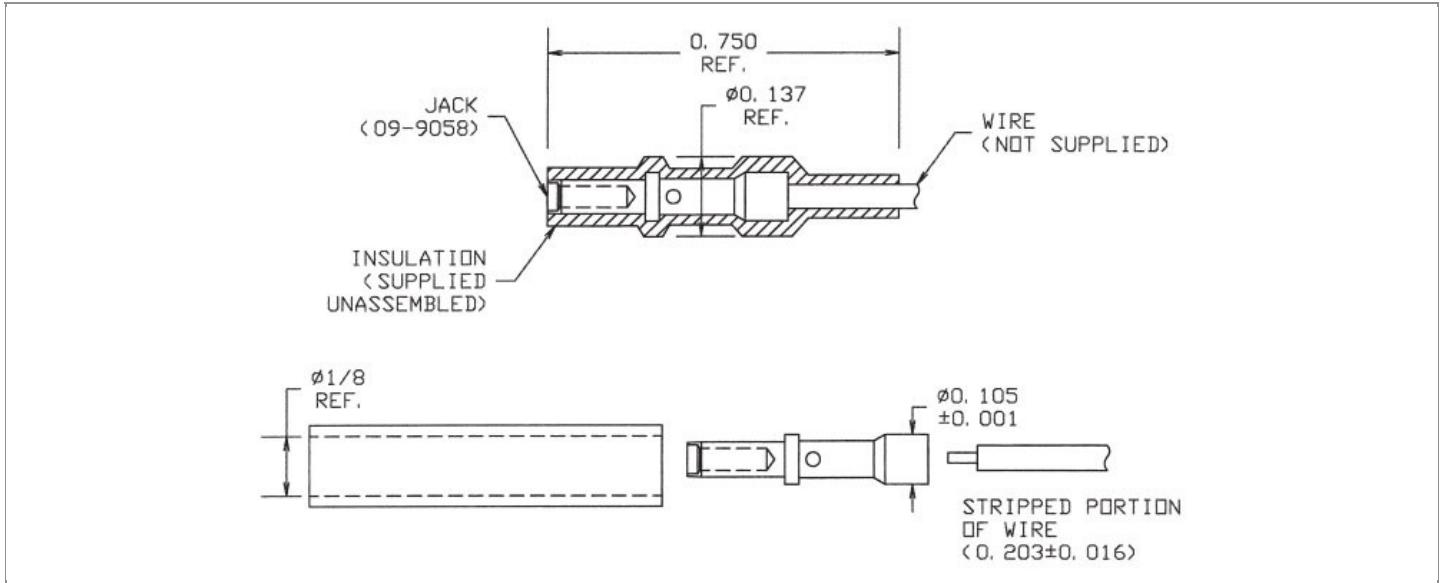

ACCEPTS PIN / PLUG / JACK SIZE	OVERALL LENGTH	MIN. HOLE DEPTH	MOUNTING ORIENTATION
0.025" ± 0.001	0.750"	0.185"	N/A
BOARD / PANEL MOUNTING METHOD	MOUNTING HOLE SIZE	BOARD / PANEL THICKNESS	FEED THRU COMBINATION
N/A	N/A	N/A	N/A

**PART NO. STRUCTURE:**

<b>09-9059</b>	-	<b>1</b>	-	<b>XX</b>	<b>XX</b>
PART SERIES		DIMENSION		FINISH	INSULATION COLOR

**MATERIAL OPTIONS:**

**09-9059-1-XXXX**

COMPONENT	MATERIAL	MATERIAL AND SPECIFICATION
BODY	BRASS	BRASS PER ASTM B16, ALLOY C36000, 1/2 HARD
SPRING (CAGE)	BERYLLIUM COPPER	BERYLLIUM COPPER PER ASTM B194, ALLOY C17200
INSULATION*	POLYOLEFIN	POLYOLEFIN PER AMS-DTL-23053/5 CLASS 1
MOUNTING BRACKET	N/A	N/A

\*For Insulation color, please see INSULATION COLOR OPTIONS on Page 2

FINISH - PLATING OPTIONS:

09-9059-1-XXXX

FINISH CODE	COMPONENT	FINISH	FINISH AND SPECIFICATION
03	BODY	GOLD	0.000010"MIN. GOLD PER ASTM B488, TYPE II, CODE C OVER 0.000100"MIN. NICKEL PER SAE-AMS-QQ-N-290, CLASS 2
	SPRING (CAGE)	GOLD	0.000030"MIN. GOLD PER ASTM B488, TYPE II, CODE C OVER 0.000100"MIN. NICKEL PER SAE-AMS-QQ-N-290, CLASS 2
	MOUNTING BRACKET	N/A	N/A
035	BODY	GOLD	0.000020"MIN. GOLD PER ASTM B488, TYPE II, CODE C OVER 0.000100"MIN. NICKEL PER SAE-AMS-QQ-N-290, CLASS 2
	SPRING (CAGE)	GOLD	0.000050"MIN. GOLD PER ASTM B488, TYPE II, CODE C OVER 0.000100"MIN. NICKEL PER SAE-AMS-QQ-N-290, CLASS 2
	MOUNTING BRACKET	N/A	N/A
04	BODY	ELECTRO-TIN	0.000100"MIN. ELECTRO-TIN PER ASTM B545 OVER 0.000100"MIN. NICKEL PER SAE-AMS-QQ-N-290, CLASS 2
	SPRING (CAGE)	BRIGHT ELECTRO-TIN	0.000200"MIN. BRIGHT ELECTRO-TIN PER ASTM B545 OVER 0.000050"MIN. NICKEL PER SAE-AMS-QQ-N-290, CLASS 2
	MOUNTING BRACKET	N/A	N/A
06	BODY	ELECTRO-TIN	0.000100"MIN. ELECTRO-TIN PER ASTM B545 OVER 0.000100"MIN. NICKEL PER SAE-AMS-QQ-N-290, CLASS 2
	SPRING (CAGE)	GOLD	0.000030"MIN. GOLD PER ASTM B488, TYPE II, CODE C OVER 0.000100"MIN. NICKEL PER SAE-AMS-QQ-N-290, CLASS 2
	MOUNTING BRACKET	N/A	N/A
063	BODY	BRIGHT TIN-LEAD	0.000200"MIN. BRIGHT TIN-LEAD (Sn93%-Pb7%) PER ASTM B545 OVER 0.000100"MIN. NICKEL PER SAE-AMS-QQ-N-290, CLASS 2
	SPRING (CAGE)	GOLD	0.000030"MIN. GOLD PER ASTM B488, TYPE II, CODE C OVER 0.000100"MIN. NICKEL PER SAE-AMS-QQ-N-290, CLASS 2
	MOUNTING BRACKET	N/A	N/A
088	BODY	BRIGHT TIN-LEAD	0.000200"MIN. BRIGHT TIN-LEAD (Sn93%-Pb7%) PER ASTM B545 OVER 0.000100"MIN. NICKEL PER SAE-AMS-QQ-N-290, CLASS 2
	SPRING (CAGE)	BRIGHT TIN-LEAD	0.000200"MIN. BRIGHT TIN-LEAD (Sn93%-Pb7%) PER ASTM B545 OVER 0.000100"MIN. NICKEL PER SAE-AMS-QQ-N-290, CLASS 2
	MOUNTING BRACKET	N/A	N/A

INSULATION COLOR OPTIONS:

09-9059-1-XXXX

INSULATION COLOR	BLACK	BLUE	GREEN	RED	WHITE	YELLOW
COLOR CODE NO.	10	16	15	12	19	14

TOLERANCES:\*

DECIMAL	FRACTIONAL	ANGULAR	DRAWING ORIGATION DATE	LAST MODIFICATION DATE
± 0.010	± 1/64	± 5 °	9/3/1998	1/1/2017

\*All dimensions are in inches.

RoHS COMPLIANCE:

09-9059-1-03XX

PART NUMBER	RoHS COMPLIANT
09-9059-1-0310	YES
09-9059-1-0312	YES
09-9059-1-0314	YES
09-9059-1-0315	YES
09-9059-1-0316	YES
09-9059-1-0319	YES

09-9059-1-035XX

PART NUMBER	RoHS COMPLIANT
09-9059-1-03510	YES
09-9059-1-03512	YES
09-9059-1-03514	YES
09-9059-1-03515	YES
09-9059-1-03516	YES
09-9059-1-03519	YES

09-9059-1-04XX

PART NUMBER	RoHS COMPLIANT
09-9059-1-0410	YES
09-9059-1-0412	YES
09-9059-1-0414	YES
09-9059-1-0415	YES
09-9059-1-0416	YES
09-9059-1-0419	YES

09-9059-1-06XX

PART NUMBER	RoHS COMPLIANT
09-9059-1-0610	YES
09-9059-1-0612	YES
09-9059-1-0614	YES
09-9059-1-0615	YES
09-9059-1-0616	YES
09-9059-1-0619	YES

09-9059-1-063XX

PART NUMBER	RoHS COMPLIANT
09-9059-1-06310	NO
09-9059-1-06312	NO
09-9059-1-06314	NO
09-9059-1-06315	NO
09-9059-1-06316	NO
09-9059-1-06319	NO

09-9059-1-088XX

PART NUMBER	RoHS COMPLIANT
09-9059-1-08810	NO
09-9059-1-08812	NO
09-9059-1-08814	NO
09-9059-1-08815	NO
09-9059-1-08816	NO
09-9059-1-08819	NO

MILITARY REFERENCE SPECIFICATIONS:

09-9059-1-03XX

PART NUMBER	MIL SPECIFICATION	MIL PART NUMBER
09-9059-1-0310	N/A	N/A
09-9059-1-0312	N/A	N/A
09-9059-1-0314	N/A	N/A
09-9059-1-0315	N/A	N/A
09-9059-1-0316	N/A	N/A
09-9059-1-0319	N/A	N/A

09-9059-1-035XX

PART NUMBER	MIL SPECIFICATION	MIL PART NUMBER
09-9059-1-03510	N/A	N/A
09-9059-1-03512	N/A	N/A
09-9059-1-03514	N/A	N/A
09-9059-1-03515	N/A	N/A
09-9059-1-03516	N/A	N/A
09-9059-1-03519	N/A	N/A

09-9059-1-04XX

PART NUMBER	MIL SPECIFICATION	MIL PART NUMBER
09-9059-1-0410	N/A	N/A
09-9059-1-0412	N/A	N/A
09-9059-1-0414	N/A	N/A
09-9059-1-0415	N/A	N/A
09-9059-1-0416	N/A	N/A
09-9059-1-0419	N/A	N/A

09-9059-1-06XX

PART NUMBER	MIL SPECIFICATION	MIL PART NUMBER
09-9059-1-0610	N/A	N/A
09-9059-1-0612	N/A	N/A
09-9059-1-0614	N/A	N/A
09-9059-1-0615	N/A	N/A
09-9059-1-0616	N/A	N/A
09-9059-1-0619	N/A	N/A

Continued on next page...

MILITARY REFERENCE SPECIFICATIONS CONTINUED:

09-9059-1-063XX

PART NUMBER	MIL SPECIFICATION	MIL PART NUMBER
09-9059-1-06310	N/A	N/A
09-9059-1-06312	N/A	N/A
09-9059-1-06314	N/A	N/A
09-9059-1-06315	N/A	N/A
09-9059-1-06316	N/A	N/A
09-9059-1-06319	N/A	N/A

09-9059-1-088XX

PART NUMBER	MIL SPECIFICATION	MIL PART NUMBER
09-9059-1-08810	N/A	N/A
09-9059-1-08812	N/A	N/A
09-9059-1-08814	N/A	N/A
09-9059-1-08815	N/A	N/A
09-9059-1-08816	N/A	N/A
09-9059-1-08819	N/A	N/A

TOOLING:

INSTALLATION TOOL: ARBOR PRESS	INSTALLATION TOOL: ANVIL (ARBOR PRESS OPERATED)	INSTALLATION TOOL: PRESS-FIT / ROLL SWAGE / RIVET PUNCH (ARBOR PRESS OPERATED)	INSTALLATION TOOL: PRESS-FIT (HAND OPERATED)	CRIMPING TOOL (COMMERCIAL VERSION)
N/A	N/A	N/A	N/A	701-2860

NOTES:

**DATASHEET NOTES**

RECOMMENDED WIRE SIZE: 20 - 22 AWG, 7 STRAND NO. 28 - 30 COPPER WIRE, PTFE INSULATED, 0.054" MAX. DIA. OVER INSULATION.

**INSTRUCTION NOTES**

STRIP 0.203" ± 0.016 LENGTH OF WIRE AND INSERT TO FULL DEPTH OF BARREL HOLE. CRIMP BARREL ONTO WIRE. SLIDE INSULATION OVER JACK AND WIRE SUCH THAT INSULATION DOES NOT EXTEND BEYOND RECEPTACLE END OF JACK. ASSEMBLY SHOULD BE HEATED AT 275 °F FOR APPROXIMATELY 2 MINUTES.